



### Model Number

**V11-W-YE2M-PVC-U**

Female cordset, M12, 3-pin, PVC cable

### Features

- UL Recognized Component
- Knurled nut suitable for tool assembly
- Immunity to vibration, with mechanical latching
- Gold-plated and machined contacts
- Protection degree IP67 / IP68 / IP69K

### Dimensions

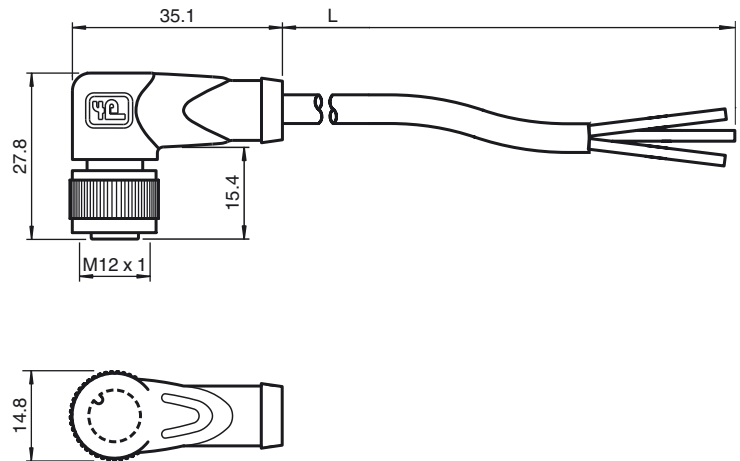

### Technical data

#### General specifications

Number of pins	3
Connection 1	socket
Construction type 1	right angle
Threading 1	M12
Connection 2	cable end
UL File Number	E231213

#### Electrical specifications

Operating voltage	$U_B$	max. 250 V AC/DC
Operating current		max. 4 A
Contact resistance		< 10 mΩ

#### Ambient conditions

Ambient temperature	Body: -40 ... 90 °C (-40 ... 194 °F) cable, flexing: -25 ... 80 °C (-13 ... 176 °F) cable, fixed: -5 ... 80 °C (23 ... 176 °F)
Pollution Degree	3

#### Mechanical specifications

Contact elements	spring-loaded contact socket	
Pin diameter	1 mm	
Protection degree	IP67 / IP68 / IP69k	
Material		
Contacts	CuSn / Au	
Contact surface	Au	
Body	TPU, black	
Cable	PVC	
Slotted nut	Diecast zinc	
Core insulation	PVC	
Cable	fine-strand, flexible	
Sheath diameter	Ø 4.3 mm	
Bending radius	> 15 x cable diameter, induced > 5 x cable diameter, fixed	
Color	yellow	
Cores	3 x 0.34 mm <sup>2</sup>	
Conductor construction	19 x 0.15 mm Ø	
Length	L	2 m
Flammability		
Contact material	94 HB	
Housing	94 V-2	
Cable	FT1	

#### Compliance with standards and directives

Standard conformity	
Protection degree	EN 60529:2000
Standards	IEC 61076-2-101:2008

### Electrical connection

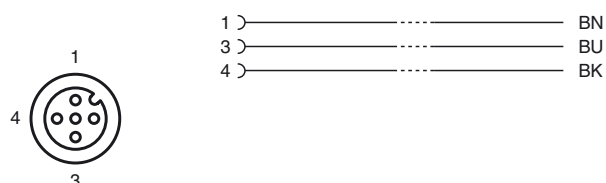



Flammability

Body: UL 94  
Line: UL 1581 Section 1061; IEC 60332-1-2:2004

Release date: 2013-08-13 17:56 Date of issue: 2013-08-13 239999-0019\_eng.xml

Refer to "General Notes Relating to Pepperl+Fuchs Product Information".